

Fits: NISSAN FRONTIER / SUZUKI EQUATOR



GROSS LOAD CAPACITY WHEN USED AS A WEIGHT CARRYING HITCH: 5,000 LBS. TRAILER WEIGHT & 500 LBS. TONGUE WEIGHT.
GROSS LOAD CAPACITY WHEN USED AS A WEIGHT DISTRIBUTION HITCH: 8,000 LBS. TRAILER WEIGHT & 800 LBS. TONGUE WEIGHT.
WARNING: * DO NOT EXCEED VEHICLE MANUFACTURER'S RECOMMENDED TOWING CAPACITY. *****



| Parts List | | | |
|------------|-----|-----------------|------------------------|
| ITEM | QTY | PART NUMBER | DESCRIPTION |
| 1 | 6 | M12-1.25 x 35mm | HEX BOLT |
| 2 | 6 | 7/16" | CONICAL TOOTHED WASHER |

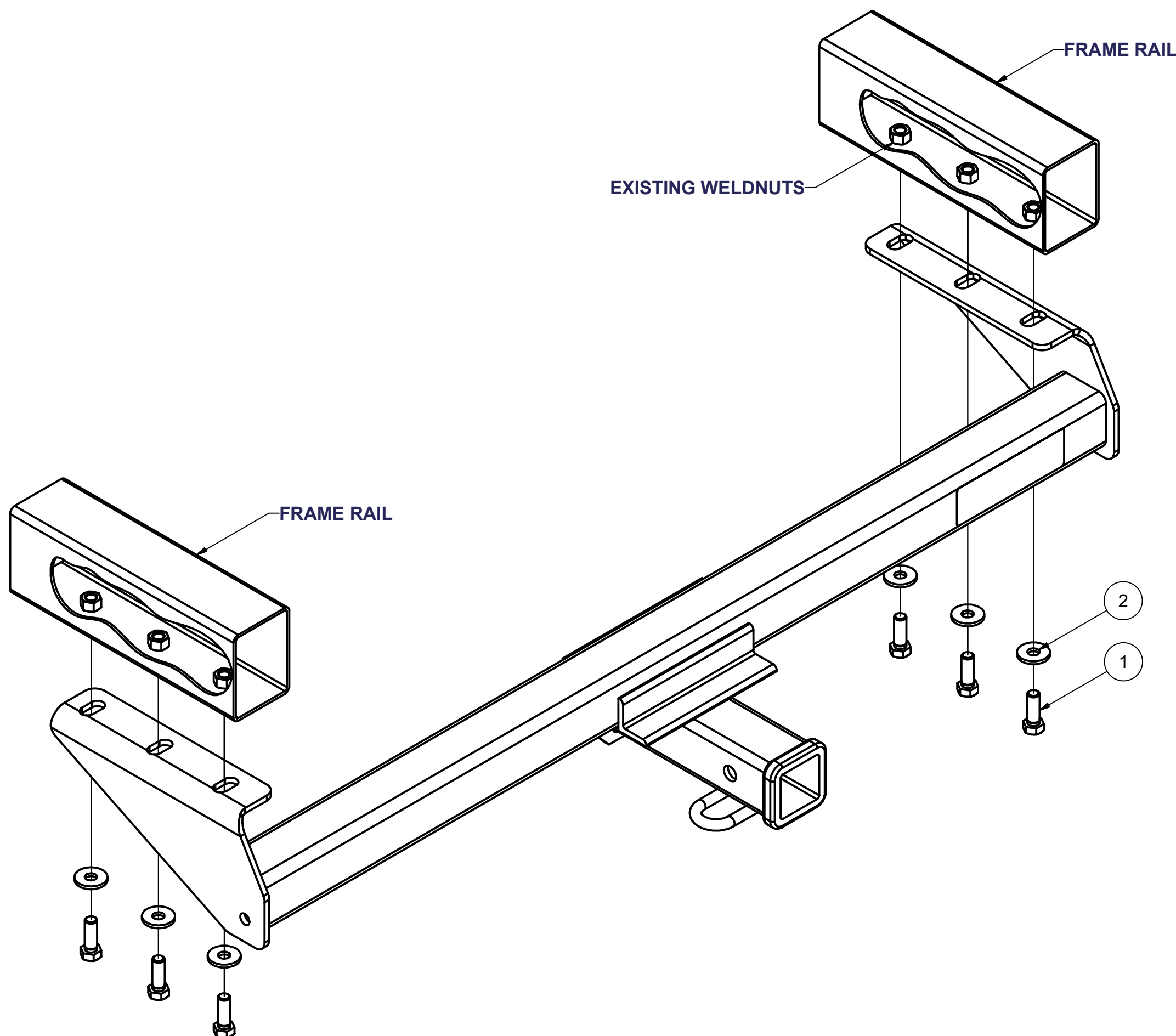

HITCH WEIGHT: 45 LBS.

INSTALL TIME

PROFESSIONAL: 15 MINUTES

NOVICE (DIY): 30 MINUTES

INSTALL NOTES:

- NO DRILLING REQUIRED

INSTALLATION STEPS

- 1) Raise hitch into position.
- 2) Secure with M12 bolts and conical washers into existing weldnuts as shown.
- 3) Torque all M12 fasteners to 86 lb-ft.

PERIODICALLY CHECK THIS RECEIVER HITCH TO ENSURE THAT ALL FASTENERS ARE TIGHT AND THAT ALL STRUCTURAL COMPONENTS ARE SOUND.