

Class III Receiver Hitch

Part No. e75ZR

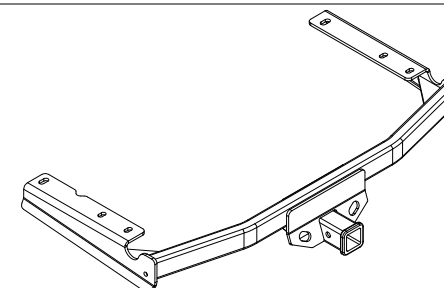

Fits: TOYOTA HIGHLANDER



GROSS LOAD CAPACITY WHEN USED AS A WEIGHT CARRYING HITCH: 5,000 LBS. TRAILER WEIGHT & 500 LBS. TONGUE WEIGHT.
WARNING: * DO NOT EXCEED VEHICLE MANUFACTURER'S RECOMMENDED TOWING CAPACITY. *****



Parts List			
ITEM	QTY	PART NUMBER	DESCRIPTION
1	6	10-10275	HHCS,M12x1.25,35,CL10.9,YZ
2	6	30-00149	WASHER, S-CON,1/2,YZ

TOOLS REQUIRED	
RATCHET	
TORQUE WRENCH	
10mm SOCKET	
12mm SOCKET	
17mm SOCKET	
19mm SOCKET	
6" EXTENSION	
SCREW DRIVER	
ROTARY TOOL (OPTIONAL)	
SAFETY GLASSES	

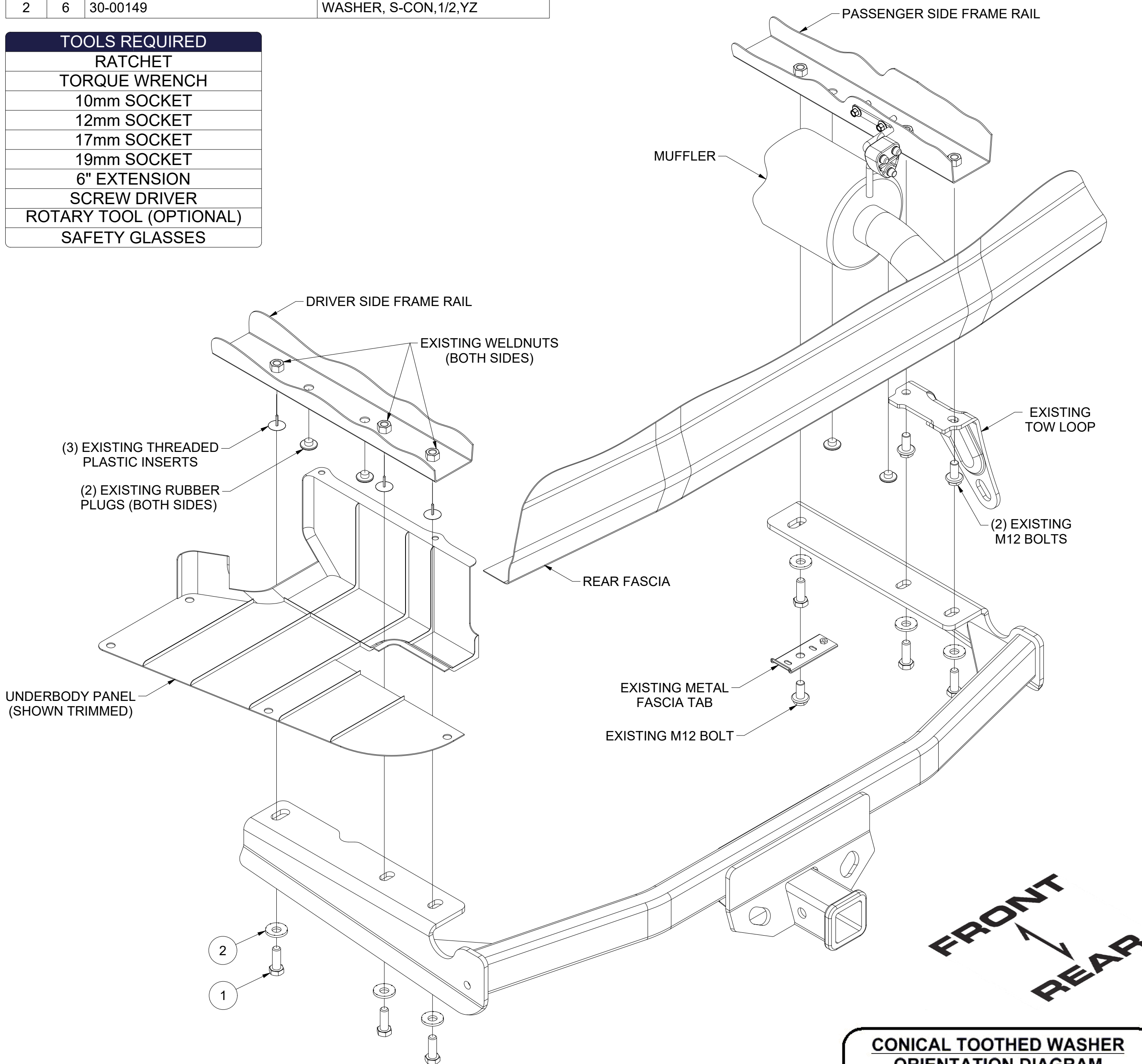

HITCH WEIGHT: 52 LBS.

INSTALL TIME

PROFESSIONAL: 30 MINUTES

NOVICE (DIY): 60 MINUTES

INSTALL NOTES:

- NO DRILLING
- PART REMOVAL
- TRIM OR REMOVE UNDERBODY PANEL

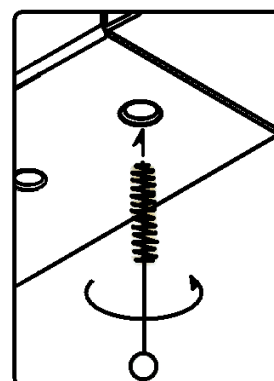

WELDNUT CLEANING

To remove debris from weldnuts in frame, spray lubricant or compressed air into hole. For heavy debris, use a small wire brush. (Be careful not to damage threads).

CONICAL TOOTHED WASHER ORIENTATION DIAGRAM

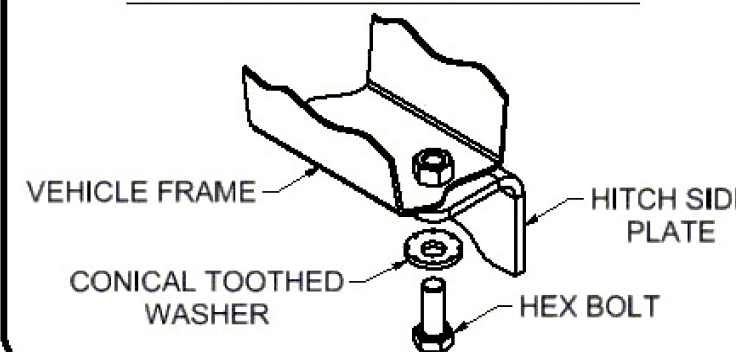

PERIODICALLY CHECK THIS RECEIVER HITCH TO ENSURE THAT ALL FASTENERS ARE TIGHT AND THAT ALL STRUCTURAL COMPONENTS ARE SOUND.

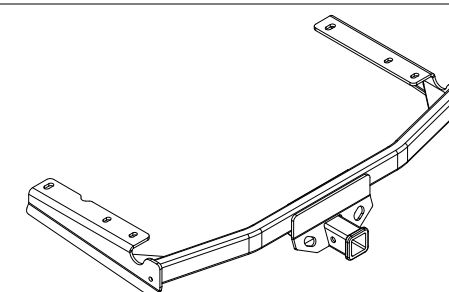

Fits: TOYOTA HIGHLANDER



GROSS LOAD CAPACITY WHEN USED AS A WEIGHT CARRYING HITCH: 5000 LBS. TRAILER WEIGHT & 500 LBS. TONGUE WEIGHT.
WARNING: * DO NOT EXCEED VEHICLE MANUFACTURER'S RECOMMENDED TOWING CAPACITY. *****

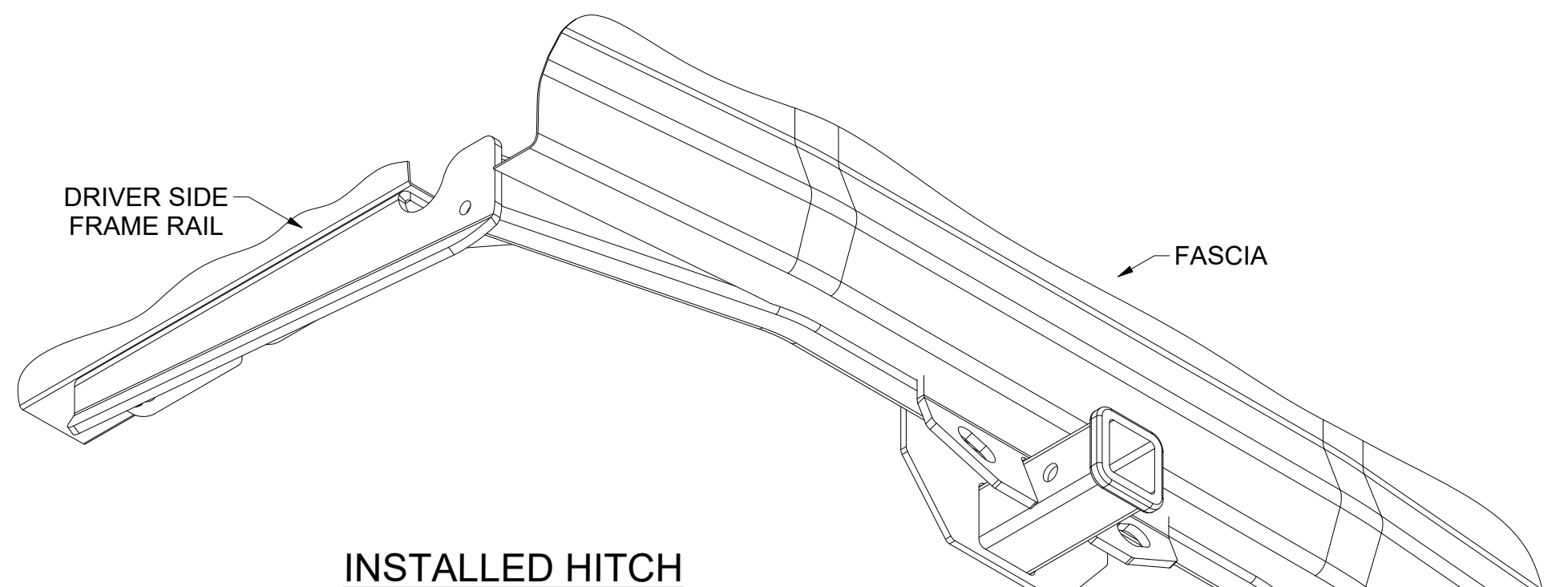

INSTALLED HITCH

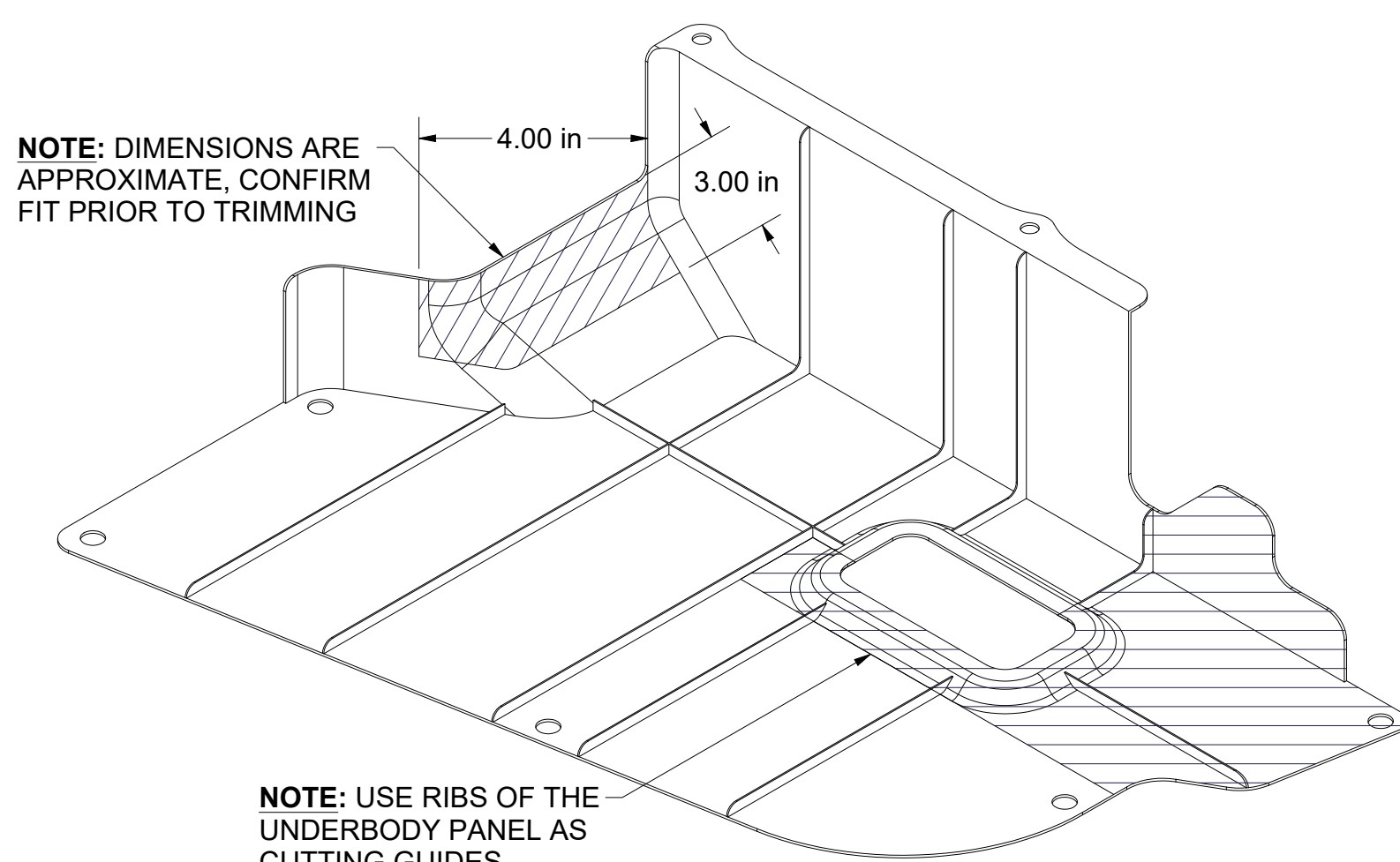

UNDERBODY PANEL TRIM DIAGRAM

INSTALLATION STEPS

1. Remove the (7) fasteners securing the driver side underbody panel. After lowering the underbody panel return it to the owner or trim and reinstall in Step (5). Remove (1) fastener from each outermost bumper support tabs and bend down.
2. Remove the (2) rubber plugs from each of the frame rails. Unscrew the (3) threaded plastic inserts from the driver side frame rail and (2) from the passenger side frame rail. Return plugs and inserts to owner.
3. Remove the M12 bolt securing the metal fascia tab to the passenger side frame rail. Return the fascia tab, tow loop, and fasteners to owner.
4. Raise the hitch over the exhaust then the fascia exhaust air deflector and align the holes in the hitch with the weldnuts in the frame. Secure the hitch to the frame using the supplied M12-1.25 hex bolts and 1/2" conical toothed washers. Torque all 12mm hardware to 86 ft-lbs. Reinstall the bumper fascia tabs removed in Step 1.
5. Mark and trim underbody panel. Reattach underbody panel using fasteners removed in Step (1).
Note: See underbody panel trim diagram. Dimensions are approximate, confirm fit prior to trimming. Use ribs of the underbody panel as cutting guides.

PERIODICALLY CHECK THIS RECEIVER HITCH TO ENSURE THAT ALL FASTENERS ARE TIGHT AND THAT ALL STRUCTURAL COMPONENTS ARE SOUND.